

MAX-UNI-S-8-2-10-W-W

160W Integrated X-Ray Source

TruFocus Ordered P/N	Min. Voltage (-kV)	Max. Voltage (-kV)	Max. Current (mA)	Max. Power (W)	Focal Spot Size (mm)	Target Angle (°)	Flux Stability (% RSD)	Target Material	Beam Angle	Cooling Method	Programmable
MAX-UNI-S-8-2-10-W-W	17	80	2	160	0.2	10°	0.01*	Tungsten (W)	X=62.75° Y=41.50°	Water	Y

*Percentage RSD average, based on data collected over 48 hour period of continual operation at TruFocus test station.

For industrial environment and applications that demand top quality and high stability



Front View



Rear View

MAX-UNI-S-8-2-10-W-W is an Integrated (UNI-Block™) X-Ray Source (160W, 80kV, 2mA). It is part of TruFocus' MAX-UNI product family and integrates TruFocus' high quality X-Ray source, an extremely stable power supply with a programmable interface in a fully shielded housing.

HIGHLIGHTS

- Control Interface:** Fully programmable control interface (rear D-Sub 25 pin connector)
- Fault Detection & Monitor:** Temperature, InterLock, Cooling Flow
- Focal Spot Size:** 0.2 mm, nominal
- Stability:** 0.01% Relative Standard Deviation (average) over a 48 hour period of continual operation

APPLICATIONS

- Analytical • Stress Analysis • Thickness Gauging • Particle Analysis • Spectroscopy Soft X-Ray • Radiology • Isotope Replacement • Fluorescence • Densitometry

MAX-UNI-S-8-2-10-W-W controlled with MAX CONTROLLER or PC/MAX Driver (USB)

Controller with Color LCD • Graphic User Interface • PC USB Interface • PC Software Driver with advanced control & detection functions • Fiber Optics/USB Interfacing for Noise Free Communication



MAX Series Controller (MAX Controller)



Front Panel Control Mode
Use MAX Series Controller to control MAX-UNI-S-8-2-10-W-W



PC Control Mode
Use a PC & MAX Controller to control MAX-UNI-S-8-2-10-W-W

HIGHLIGHTS

- Programmable kV input • Programmable mA input
- Fault Detection & Monitoring
- HV Monitor output • mA Monitor output • Calibration output • Interlock Status input • System Fault detection • Pressure Fault Detection • Tube Over-Power Fault Detection • Tube Over-Power Monitor output kV input • Programmable mA input.

OTHER APPLICATIONS

Tests of X-Ray backup units
Incoming Tests of new units

- Simple to set up
- Safe & time saving
- Minimum space

Specifications

MAX-UNI-S-8-2-10-W-W

Control & Calibration Interface (25-pin D-Sub Connector)

PIN#	PARAMETER	MIN	MAX
2	+10 VDC Reference Output	+9.95	+10.05
3	kV Program Input, full scale	0	+10 VDC
4,6	kV mA Program Return, floating	-2 VDC	+2 VDC
5	mA Program Input, full scale	0	+10 VDC
7	kV Monitor Output, full scale	0	+10 VDC
8	mA Monitor Output, full scale	0	+10 VDC
	HV Monitor Accuracy		2%
	mA Monitor Accuracy		2%
9	Monitor Return, floating	-2 VDC	+2 VDC
Control & Fault Detection			
1, 14	Ground and Logic Return	0	0
15	Enable Input low level interlock	+3.5 VDC	+36 VDC
16	Fault Output	+4.5 VDC	+5.5 VDC
17	Pressure Fault	200 Kpa	500 Kpa
18	Temperature Fault	0 C	65 C
	Over Voltage Tube Fault	-80 kV	-84kV
	Over Current Tube Fault	2.0 mA	2.5 mA
	Over Power Tube Fault	160 W	210 W
19	Ready Output	+4.5 VDC	+5.5 VDC
20	Ready Output	+4.5 VDC	+5.5 VDC
21	Tube Power Monitor, full scale		+2 VDC
Power Inputs			
10	+ VDC input for filament: Voltage	22 VDC	32 VDC
	+ VDC input for filament: Current	0.2 AMP	0.8 A
11,12,13	+ VDC Input for HV: Voltage	24 VDC	32 VDC
	+ VDC input for HV: Current	0 AMP	11 A
	+ VDC input for HV: Power	0 WATT	250 W
23,24,25	- VDC input supply returns	0	0
	Fusing on power inputs		18 A

System Parameters

Parameter	Value	Unit
Target Voltage	-17 to -80	kV
Target Current	0-2.0	mA
Maximum Power	160	W
Focal Spot Size	0.2, nominal	mm
Focal Spot Shape	Circular	—
Beam Angle	X=62.75° Y=41.5°	degree
Operation	Continuous	—

X-Ray Tube

Parameter	Description
X-ray Tube	Glass / Metal
Filament	3 V at 3.5 mA (max)
Target Material	Tungsten
Target Angle	10°
Window Material	Beryllium
Window Thickness	.005 "
Window Type	Side Window
Operating / Storage Temp. (Max.)	+10 °C to +60 °C / 0 °C to +60 °C
Operating / Storage Humidity (Max.)	85 % RH
Cooling Method	Water + 10% Propylene glycol
Weight	14 lbs
Flux Stability	0.01% *

***Flux Stability:** Percentage RSD average, based on data collected over 48 hour period of continual operation at TruFocus test station.

OUTLINE DRAWING

Drawing# & Version:	DW-MAX-UNI-S-8-2-10-W-W -V01
TruFocus P/N:	MAX-UNI-S-8-2-10-W-W
Unit:	Inch

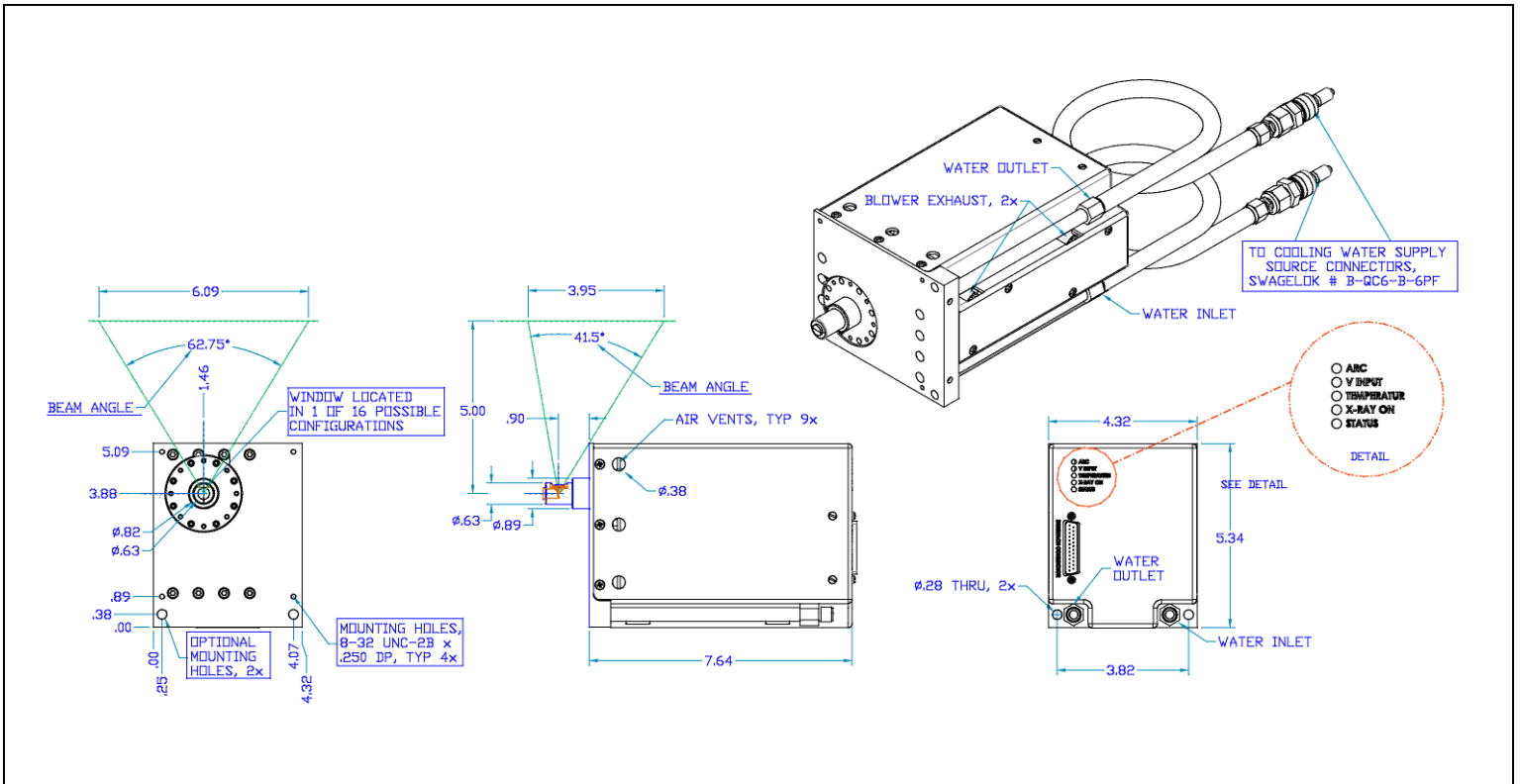

Standard Window Orientation



Caution

X-Ray Radiation



1. X-Ray radiation is harmful to the human body. It is necessary to take all safety precautions when operating this device.
2. The x-ray tube should be installed in an x-ray shielded cabinet to avoid exposure. It is recommended that the safety interlock system be used at all times.
3. It is the customer's responsibility to provide shielding for the use of this device.

Warranty Information

This x-ray tube is warranted to be free of defects in materials and workmanship for a period of 365 days (1 year). This warranty is limited to repair or replacement of defective products only. This warranty replacement cost to customer shall be prorated over the duration of the warranty period. The warranty period commences on the date of installation, but no later than 30 days from the date of shipment from TruFocus to the customer. Any loss, damage, failure and/or malfunction relating in any way to accident, abuse, alteration, misuse, neglect, fitting, disassembly, attempted repair, storage, adjustments of the electronics, or failure to use the tube within the specifications or operating instructions provided by TruFocus, or the lack of proper routine maintenance and care of the tube or system in which it is installed are expressly denied coverage under this warranty.

Subject to local and technical requirements and regulations. Availability of product in this promotional material may vary. Please consult with our office staff for availability.

Information furnished by TruFocus is believed to be reliable. However, no responsibility is assumed for possible inaccuracies or omissions. Specifications are subject to change without notice. Patent rights are granted to any and all of the circuits described herein. © 2013 TruFocus Corporation